

# INTEGRAL-BONNET NEEDLE VALVES

H-300U SERIES

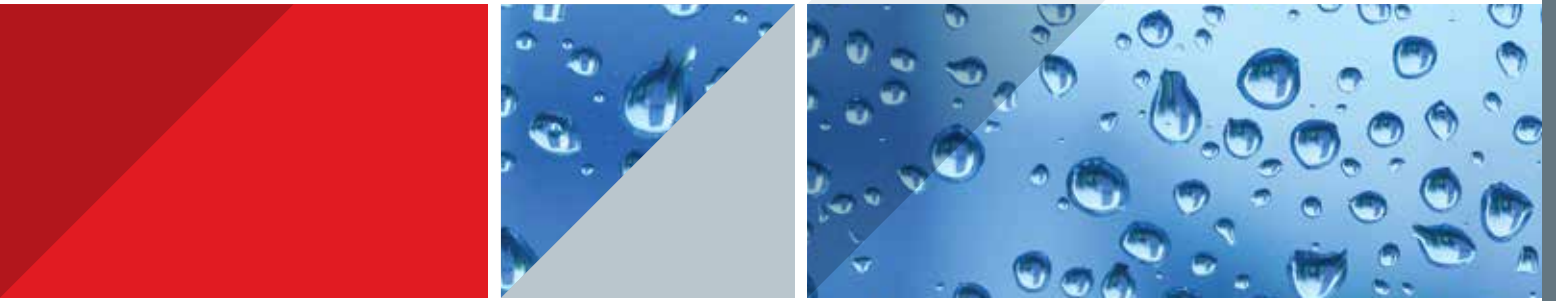

**FEATURES**

- Certified for ISO 15848-1:2006(E)
- Straight and angle pattern
- Stainless steel and brass construction
- MAWP 5000 psi (345 bar), MAWT 446°F (230°C)
- Flow coefficient (Cv) 0.09 to 1.8
- Sizes: 1/8" to 3/4" (3mm-12mm)
- Round plastic, round aluminum, and metal bar handles
- Variety of stem types
- Packing bolt for easy panel mounting, no packing disassembling is required
- Chevron stem packing provides lowest operation torques
- Belleville washers to compensate packing wear
- Special synthetic, anti-seize stem lubricant for best resistance to hot media

MATERIAL OF CONSTRUCTION			
No.	Component	Qty.	Material
1	Handle	1	Phenolic
2	Set Screw	1	St.St.316
3	Packing Bolt	1	St.St.316
4	Belleville Washer	2	St.St.302
5	Gland	2	St.St.316
6	Upper Packing	1	PTFE
7	Bottom Packing	1	PTFE
8	A Regulating Stem	1	St.St.316 with surface treatment
	B V-Stem	1	St.St.316 with surface treatment
	C Non-Rotatin Stem	1	St.St.316 with surface treatment
	D Soft Seat Stem	1	St.St.316 with surface treatment
9	Panel Nut	2	St.St.316
10	Body	1	St.St.316

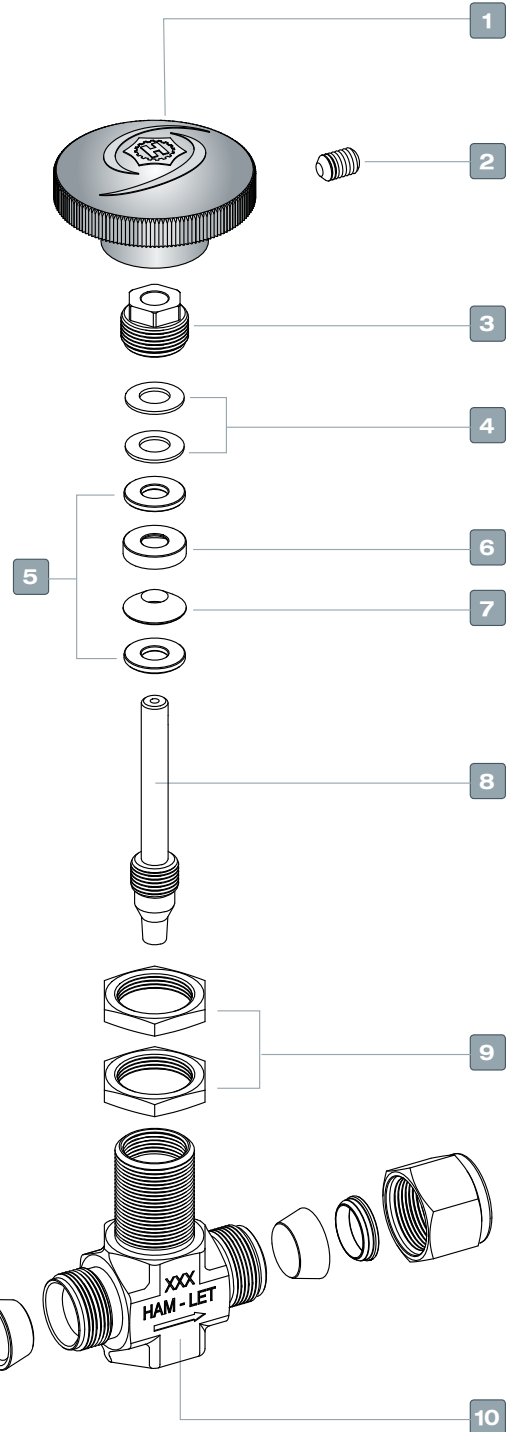
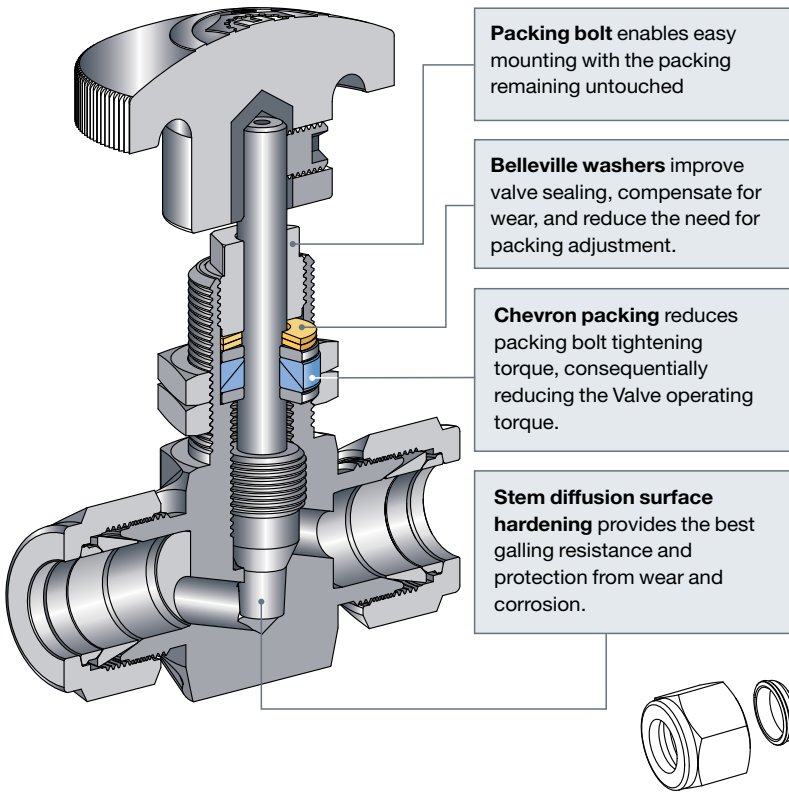

## GENERAL

The H-300U Series is an advanced high pressure instrumentation needle valve for shut-off service, its packing bolt design for easy mounting being the best solution for instrumentation panels.

This compact valve enables a relatively high level of flow regulation and long-life service.

Special stem surface treatment, based on low temperature carbon diffusion, enables higher surface hardness with improved wear resistance, resistance to system contaminations and optimal operational torque.

STANDARD CONFIGURATION DIMENSIONS																					
Basic Ordering Number	Orifice mm (in) S/A	Cv	Connection Size		A		A1		A2		A3		B		C	D	E	F	G	H	T max
			Inlet	Outlet	mm	in	mm	in	mm	in	mm	in	mm	in	mm	in	mm (in)	mm (in)	mm (in)	mm (in)	mm (in)
H-300	2.0 (0.08)	0.09	3mm LET-LOK®	3mm LET-LOK®	50.8	2.00	25.4	1.00	25.4	1.00	25.4	1.00	33.4	1.31	10.0 (0.39")	7.95 (0.31")	35.1 (1.38")	13.0 (0.51")	63.5 (2.50")	15.9 (5/8")	10.0 (0.39")
H-300			1/8" LET-LOK®	1/8" LET-LOK®	50.8	2.00	25.4	1.00	25.4	1.00	25.4	1.00	33.4	1.31							
H-395			1/8" MNPT	1/8" LET-LOK®	45.3	1.78	19.9	0.78	25.4	1.00	19.9	0.78	33.4	1.31							
H-300	4.4 (0.172)	0.37	1/4" LET-LOK®	1/4" LET-LOK®	58.8	2.31	29.4	1.16	29.4	1.16	29.4	1.16	37.3	1.47	14.3 (0.56")	16.5 (0.65")	47.8 (1.88")	20.0 (0.79")	78.4 (3.09")	23.8 (15/16")	12.0 (0.49")
H-300			6mm LET-LOK®	6mm LET-LOK®	58.8	2.31	29.4	1.16	29.4	1.16	29.4	1.16	37.3	1.47							
H-300			8mm LET-LOK®	8mm LET-LOK®	58.8	2.31	29.4	1.16	29.4	1.16	29.4	1.16	37.3	1.47							
H-310			1/8" FNPT	1/8" FNPT	41.2	1.62	20.6	0.81	20.6	0.81	20.6	0.81	28.5	1.12							
H-380			1/8" MNPT	1/8" MNPT	50.8	2.00	25.4	1.00	25.4	1.00	25.4	1.00	33.3	1.31							
H-380			1/4" MNPT	1/4" MNPT	50.8	2.00	25.4	1.00	25.4	1.00	25.4	1.00	33.3	1.31							
H-395			1/4" MNPT	1/4" LET-LOK®	54.8	2.16	25.4	1.00	29.4	1.16	25.4	1.00	37.3	1.47							
H-300	6.4 (0.25)	0.73	3/8" LET-LOK®	3/8" LET-LOK®	66.0	2.60	33.0	1.30	33.0	1.30	33.0	1.30	49.5	1.95	19.5 (0.77")	20.0 (0.79")	47.8 (1.88")	26.0 (1.02")	105.6 (4.16")	30.2 (1-3/16")	22.0 (0.87")
H-300			10mm C	10mm LET-LOK®	66.4	2.62	33.2	1.31	33.2	1.31	33.2	1.31	49.7	1.96							
H-300			1/2" LET-LOK®	1/2" LET-LOK®	71.6	2.82	35.8	1.41	35.8	1.41	35.8	1.41	52.3	2.06							
H-300			12mm LET-LOK®	12mm LET-LOK®	71.6	2.82	35.8	1.41	35.8	1.41	35.8	1.41	52.3	2.06							
H-310			1/4" FNPT	1/4" FNPT	54.0	2.12	27.0	1.06	27.0	1.06	27.0	1.06	43.5	1.71							
H-380			3/8" MNPT	3/8" MNPT	57.0	2.24	28.5	1.12	28.5	1.12	28.5	1.12	45.0	1.77							
H-385			1/4" MNPT	1/4" FNPT	58.5	2.30	31.5	1.24	27.0	1.06	28.5	1.12	43.5	1.71							
H-385			3/8" MNPT	3/8" FNPT	56.5	2.22	28.5	1.12	28.0	1.10	28.5	1.12	44.5	1.75							
H-395	3/8" MNPT	3/8" LET-LOK®	61.5	2.42	28.5	1.12	33.0	1.30	28.5	1.12	49.5	1.95									
H-300	9.5 (0.375)	1.8	3/4" LET-LOK®	3/4" LET-LOK®	97.0	3.82	48.5	1.91	48.5	1.91	48.5	1.91	68.5	2.70	19.5 (0.77")	20.0 (0.79")	47.8 (1.88")	26.0 (1.02")	105.6 (4.16")	30.2 (1-3/16")	22.0 (0.87")
H-310			3/8" FNPT	3/8" FNPT	76.2	3.00	38.1	1.50	38.1	1.50	38.1	1.50	58.1	2.29							
H-310			1/2" FNPT	1/2" FNPT	76.2	3.00	38.1	1.50	38.1	1.50	38.1	1.50	58.1	2.29							
H-380			1/2" MNPT	1/2" MNPT	76.2	3.00	38.1	1.50	38.1	1.50	38.1	1.50	58.1	2.29							
H-385			1/2" MNPT	1/2" FNPT	76.2	3.00	38.1	1.50	38.1	1.50	38.1	1.50	58.1	2.29							

\* Dimensions for metal handle option

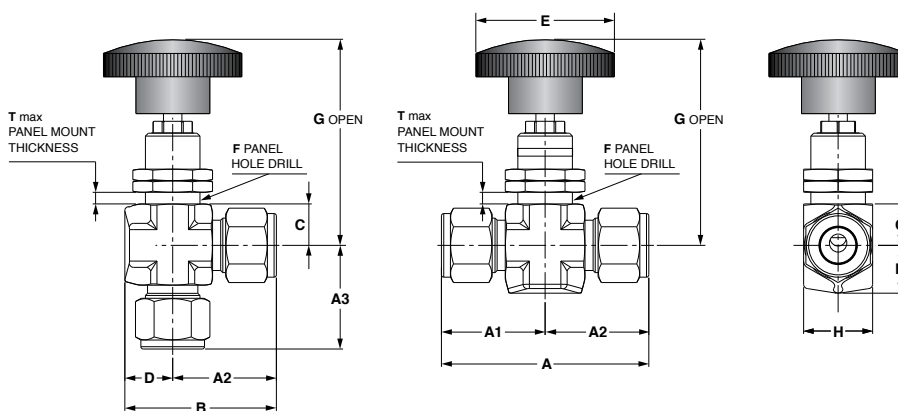

## STEM OPTIONS

H-300U needle valves are available with a choice of stem tips:



**8A Regulating:**  
Used where some degree of flow control is required.



**8B V-Stem:**  
Standard stem tip used for the on/off operation in general-purpose liquids and gas service.



**8C Non-Rotating Stem:**  
Typically used in high-cycle applications to extend valve life and prevent stem rotation inside the body tip, a suitable selection for gaseous high pressure applications.



**8D Soft Seat:**  
A soft seat tip requires a lower seating torque than a metal stem tip; the best choice for clean gaseous high pressure applications; MAWT is 200°F (93°C).

### FLOW DATA: FLOW COEFFICIENT VS. HANDLE TURNS

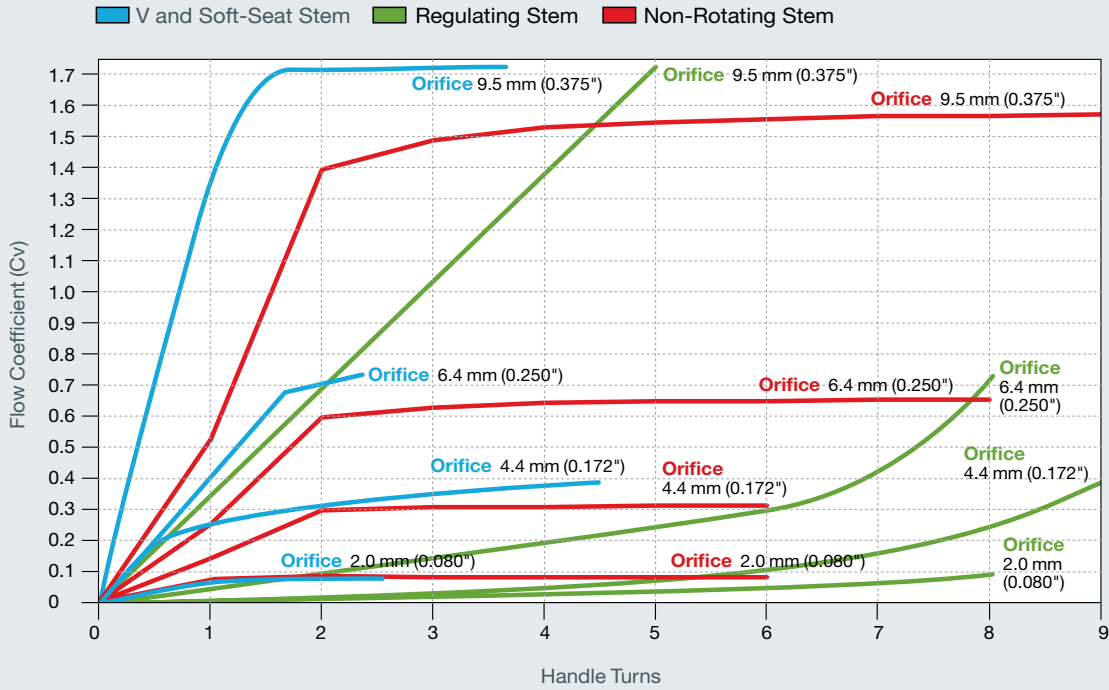

### PRESSURE TEMPERATURE RATING

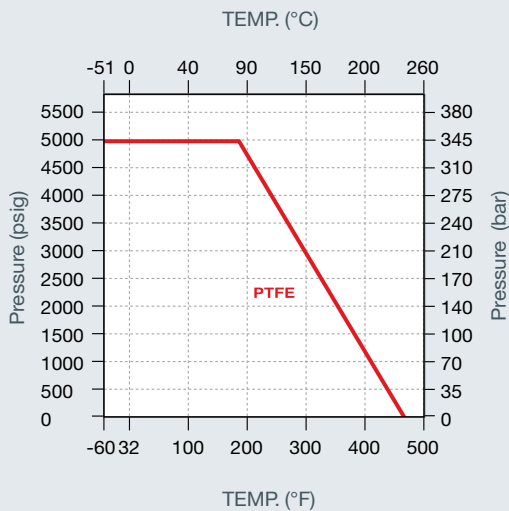

### TECHNICAL DATA

The following table contains the temperature and pressure ratings for a standard valve with PTFE packing.

Body Material	Stem Type	Rating	
		Temperature	Pressure
316 St.St.	All St.St. Stems	-51°C to 230°C (-60°F to 446°F)	5000 psi
	PCTFE	-46°C to 93°C (-51°F to 200°F)	5000 psi
Brass	Regulating & V-Stem	-46°C to 200°C (-51°F to 392°F)	3000 psi
	PCTFE	-46°C to 93°C (-51°F to 200°F)	3000 psi

\* Extreme temperature fluctuations may require packing adjustment.

#### Notes:

- The H-300U was designed for high pressure services where moderately uncontaminated media is used
- For steam applications, it is recommended to select one of HAM-LET severe service needle valves
- For oxygen applications, select the oxygen clean treatment option.
- For relatively high pressure pure oxygen applications, assure that the selected valve is tested and found to meet the specific application requirements

## CLEANING & PACKAGING

Every H-300U series needle valve is cleaned in accordance with Standard Cleaning and Packaging (procedure 8184). Oxygen Clean & Lubricant Free Cleaning and packaging, in accordance with Special Cleaning and Packaging (procedure 8185), is available as an option.

## TESTING

The H-300U Series Needle Valve design has been tested for Proof and Burst. Every H-300U Needle Valve is factory tested with nitrogen at 1000 psi (69 bar). The maximum allowable leakage across the seat is 0.1 std cc/min.

## PACKING ADJUSTMENT

Due to the varied service applications of the valve, packing adjustment may occasionally be necessary. Packing is factory adjusted to 1000 psig service. Initial packing adjustment is recommended after installation and prior to start-up. See packing adjustment procedure No.3901882 on the website.

## H-300U SERIES ORDERING INFORMATION

**OPTIONAL**

H-3
00 U-
SS
-
L
-
V
-
1/4
-
RS
-
[ ]
[ ]

Valve Series	End Connection	Stem Designator	End Connection Size	Handle Type	Pattern Designator	Treatment
<b>Valve Type</b>	<b>L</b> - LET-LOK®	<b>V</b> - V Stem	<b>1/8</b> 3MM	<b>RS</b> -Black Plastic	<b>Blank</b> - Straight	<b>BLANK</b> - Standard Cleaning & Passivation
<b>00</b> - LET-LOK® End	<b>N</b> - NPT	<b>R</b> - Regulating Stem	<b>1/4</b> 6MM	<b>RAS</b> -Black Aluminum	<b>A</b> - Angle	<b>OC</b> - Oxygen Clean
<b>10</b> - Female End	<b>R</b> - ISO Tapered	<b>K</b> - Soft Seat PCTFE Stem	<b>3/8</b> 8 MM	<b>RAR</b> -Red Aluminum		<b>LF</b> - Lubricant Free
<b>80</b> - Male End	<b>NL</b> - NPT to LET-LOK®	<b>NR</b> - Non-Rotating Stem	<b>1/2</b> 10MM	<b>RAB</b> -Blue Aluminum		
<b>85</b> - Male to Female End	<b>HL</b> - Single Ferrule		<b>3/4</b> 12MM	<b>RAG</b> -Green Aluminum		
<b>95</b> - Male to LET-LOK®	<b>G</b> - ISO Parallel			<b>RAY</b> -Yellow Aluminum		
<b>Body Material</b>	<b>GL</b> - Face Seal Ends			<b>M</b> -Metal Bar SS316		
<b>SS</b> - 316SS						
<b>B</b> - Brass						

Spare Round-Handle Kits are available for each valve.



## SPARE KITS

Series	End Size	Seal Kit*	Handle Kit**
<b>H-380U</b> Male to Male	1/8, 1/4	Z-300U-SK-1/4-P	Z-300U-HK-1/4- <input type="checkbox"/>
	3/8	Z-300U-SK-1/2-P	Z-300U-HK-1/2- <input type="checkbox"/>
	1/2, 3/4	Z-300U-SK-3/4-P	Z-300U-HK-3/4- <input type="checkbox"/>
<b>H-310U</b> Female to Female	1/8	Z-300U-SK-1/4-P	Z-300U-HK-1/4- <input type="checkbox"/>
	1/4	Z-300U-SK-1/2-P	Z-300U-HK-1/2- <input type="checkbox"/>
	3/8, 1/2	Z-300U-SK-3/4-P	Z-300U-HK-3/4- <input type="checkbox"/>
<b>H-395U</b> Male to LET-LOK®	1/8, 1/4	Z-300U-SK-1/4-P	Z-300U-HK-1/4- <input type="checkbox"/>
	3/8	Z-300U-SK-1/2-P	Z-300U-HK-1/2- <input type="checkbox"/>
<b>H-385U</b> Male to Female	1/4	Z-300U-SK-1/2-P	Z-300U-HK-1/2- <input type="checkbox"/>
	3/8	Z-300U-SK-1/2-P	Z-300U-HK-1/2- <input type="checkbox"/>
	1/2	Z-300U-SK-3/4-P	Z-300U-HK-3/4- <input type="checkbox"/>
<b>H-300U</b> LET-LOK®	1/8, 1/4, 3MM, 6MM, 8MM	Z-300U-SK-1/4-P	Z-300U-HK-1/4- <input type="checkbox"/>
	3/8, 1/2, 10MM, 12MM	Z-300U-SK-1/2-P	Z-300U-HK-1/2- <input type="checkbox"/>
	3/4	Z-300U-SK-3/4-P	Z-300U-HK-3/4- <input type="checkbox"/>

\*Seal Kit contains packing and packing instructions  
 \*\*Handle Kit contains handle and set screw.

Handle type per "How to Order"

### Warning!

The system designer and user have the sole responsibility for selecting products suitable for their special application requirements, ensuring their safe and trouble-free installation, operation, and maintenance. Application details, material compatibility and product ratings should all be considered for each selected product. Improper selection, installation or use of products can cause property damage or personal injury.

H-300U, Rev.02, January 2014

